

R00DR

March 27, 2000

Dear Blue Bird Owner:

This notice is sent to you in accordance with the requirements of the National Traffic and Motor Vehicle Safety Act.

Blue Bird Body Company has determined that a defect which relates to motor vehicle safety exist in certain 1998, 1999 and 2000 year model Blue Bird All American **front** and **rear** engine school and transit buses and TC/2000, Q'Bus and Commercial Series, **rear** engine school and transit buses, all equipped with Bendix ABS (anti-lock) brakes. Blue Bird is conducting a recall to correct this defect.

The defect involves the primary and secondary brake treadle valve airlines. These airlines were installed incorrectly.

The defect involves the primary and secondary brake treadle valve airlines. These airlines were installed incorrectly. Blue Bird has determined that it is unacceptable to have brake systems plumbed inconsistent with intended design. Further, future maintenance might be affected by this inconsistency. Therefore, Blue Bird is conducting a recall to modify the units affected to conform to intended design. All affected units must be inspected and, if airlines are found to be installed incorrectly, must be modified according to the attached instructions.

Your Blue Bird bus (es) affected by recall R00DR are identified by body serial number(s) on the enclosed reply sheets. Your buses should be inspected and if necessary modified according to the instructions provided.

If you no longer own the subject bus (es), please complete the appropriate section of the yellow reply sheet and return to Blue Bird in the enclosed pink postage prepaid envelope.

You may perform this modification yourself or have the work done by a qualified repair facility convenient to you. You may contact your Blue Bird distributor for assistance. No parts are required to complete this modification.

R00DR

Page 2

Upon completion of the recall, the owner should complete and return the pink reply sheet in the postage-prepaid envelope provided. The owner may request reimbursement of labor costs by completing the appropriate section of the pink reply sheet. If repair is performed by other than the owner or a Blue Bird distributor, attach a copy of the paid work order/invoice to the reply sheet. Time required to perform recall R00DR is 0.2 hours per bus.

Important: Your prompt return of the pink reimbursement sheet, complete with the correct Body Serial Numbers, permits Blue Bird to update the record indicating recall has been completed and prevents the mailing of a second notice. This is much appreciated. We regret any inconvenience this may have caused.

If Blue Bird Body Company should fail to or is unable to remedy this condition without charge to you, you may contact:

**ADMINISTRATOR
NATIONAL HIGHWAY TRAFFIC SAFETY ADMINISTRATION
WASHINGTON, D.C. 20590**

or you may call The National Highway Traffic Safety Administration toll free at:

1-800-424-9393

Washington D.C. residents may call: 202-366-0123.

Questions regarding this recall campaign should be directed to me at (912) 822-2242.

Thank you,

Bill Coleman
Recall Administrator

**BLUE BIRD BODY COMPANY RECALL R00DR
BENDIX R12DC RELAY VALVE PLUMBING MODIFICATION
INSTRUCTIONS**

The Bendix R12DC relay valve is located on the chassis crossmember in front of the rear axle. The Bendix R12DC relay valve should have two 3/8" air lines attached to the top portion of the valve. A 3/8" black airline should be attached to the top of the valve (primary port) and a 3/8" red (or brown) airline should be attached to the side adjacent to top port (secondary port). See Figure 1.

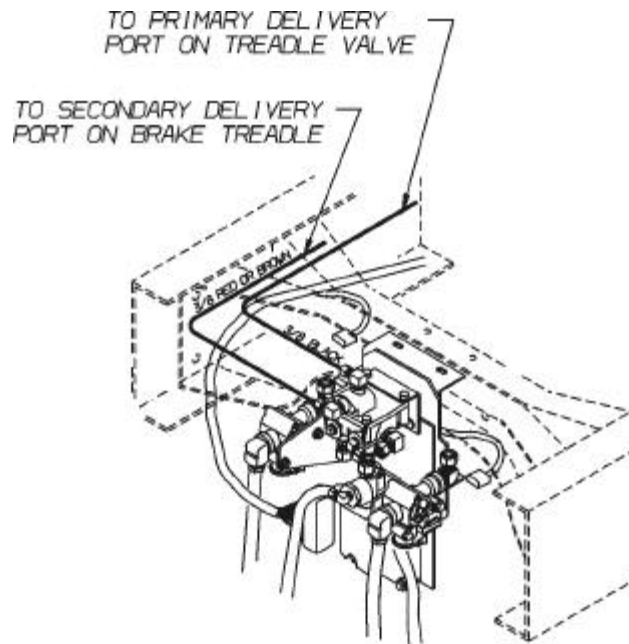

Figure 1

INSPECTION

1. Apply parking brake.
2. Remove keys from ignition.
3. Chock wheels.
4. Inspect airline connections at the Bendix R12DC relay valve.
5. If airlines are plumbed according to Figure 1, no further action is necessary. Remove wheel chocks.
6. If not, proceed to instructions for airline relocation on page 2.

AIRLINE RELOCATION FOR SERVICE LINES ON R12 RELAY VALVE

1. Remove keys from ignition.
2. Chock wheels.
3. Drain all air tanks.
4. Using a 5/8" open end wrench, remove the 3/8" black airline and the 3/8" red (or brown) airline from the Bendix R12DC relay valve.
5. Install the 3/8" black airline in the top port (primary port) of the R12DC relay valve and the 3/8" red (or brown) airline into the side port (secondary port) adjacent to the top port (See Figure 1 on page 1).
6. Close air tank drain valves.
7. Start engine and build up air pressure.
8. Stop engine. Remove key.
9. Have someone apply service brakes and check repositioned airlines for leaks.
10. Remove wheel chocks.