

R01EV

April 27, 2001

Dear Blue Bird Owner:

This notice is sent to you in accordance with the requirements of the National Traffic and Motor Vehicle Safety Act.

Blue Bird Body Company has determined that certain Blue Bird LTC 40 coaches do not conform to the requirements of Federal Motor Vehicle Safety Standard No. 221 pertaining to "Air Brake Systems". On subject buses, the brake system does not have an R12DC valve or secondary control line in the braking system as required, which could result in increased emergency stopping distances.

Blue Bird Body Company's evaluation of the risk to motor vehicle safety reasonably related to this non-compliance is reduced emergency braking ability. Blue Bird is conducting a recall to correct this non-compliance.

You should have this non-compliance corrected immediately. Your Blue Bird bus(es) affected by Recall R01EV are identified by body serial number(s) on the enclosed reply sheets. If you no longer own the subject bus(es), please complete the appropriate section of the yellow reply sheet and return to Blue Bird in the enclosed pink postage prepaid envelope.

To receive modification kits, verify correct shipping address, sign and return the enclosed **yellow** parts request sheet to Blue Bird in the enclosed pink postage prepaid reply envelope. Modification parts will be available beginning April 30, 2001. Modification parts will be shipped "No Charge" to you via UPS or common carrier.

You may perform this modification yourself or have the work done by a qualified repair facility convenient to you. You may contact your Blue Bird distributor for assistance.

Upon completion of the recall, the owner should complete and return the pink reply sheet in the pink postage prepaid reply envelope provided. The owner may request reimbursement of labor costs by completing the appropriate section of the pink reply sheet. If repair is performed by someone other than the owner or a Blue Bird distributor, attach a copy of the paid work order/invoice to the reply sheet.

Time required to complete recall R01EV is 20 hours per bus.

Important: Your prompt return of the pink reimbursement sheet, complete with the correct Body Serial Numbers, permits Blue Bird to update the record indicating recall has been completed and prevents the mailing of a second notice. This is much appreciated. We regret any inconvenience this may have caused.

If Blue Bird Body Company should fail to or is unable to remedy this condition without charge to you, you may contact:

**ADMINISTRATOR
NATIONAL HIGHWAY TRAFFIC SAFETY ADMINISTRATION
WASHINGTON, D.C. 20590**

or you may call The National Highway Traffic Safety Administration toll free at:

1-888-327-4236

Questions regarding this recall campaign should be directed to me at (912) 822-2242.

Thank you,

Bill Coleman
Recall Administrator

RECALL R01EV
INSTRUCTIONS FOR INSTALLING R12DC BRAKE VALVE AND SECONDARY
CONTROL LINE ON LTC 40 COACHES

1. Park vehicle on level surface and remove ignition key.
2. Chock wheels.
3. Drain all the air tanks for the brake system.
4. The rear brake valves and ABS modulators are located in front of the rear drive axle. See Illustration 1 to identify the brake system components that must be removed in the following steps:
 - A. Disconnect all air lines to the existing service brake valve assy (Item 3). Remove the existing valve assy (Item 3) with fitting and discard. (NOTE 1: The entire brake assembly panel may be removed to facilitate replacing service brake valve.)
 - B. Remove two (2) 36-inch hose assemblies (Item 17) and bushings (Item 19) from the modulator to the service brake chambers. Discard these two hoses and bushings.
 - C. Remove the 45 degree street elbows (Item 26) and 90 degree street elbows (Item 14) from both modulators. Discard elbows.
 - D. Disconnect the wiring harness for each modulator. Remove modulators by removing two 5/16 bolts, washers, and nuts for both modulators. Discard fasteners.
5. See Illustration 2 to identify and install the new brake components in the following steps:
 - A. Attach two ABS modulator mounting brackets # 0031446 (Item 2) to existing ABS brake valve mounting bracket (Item 1) with four (4) 5/16 –18 x 7/8 Grade 8 Capscrews BB # 0854414 (Item 24), four (4) flat washers BB # 2001048 (Item 23), and 5/16-18 nuts BB # 0829390 (Item 22). Tighten to 10-12 Ft. LB.
 - B. Re-orient ABS modulators. Attach two ABS modulators (Item 4) to ABS modulator brackets # 0031446 (Item 2) with four (4) 5/16 –18 x 3 ½ Grade 8 Capscrews BB # 1226877 (Item 21), four (4) flat washers BB # 2001048 (Item 23), and 5/16-18 nuts BB # 0829390 (Item 22). Tighten to 10-12 Ft. LB.

- C. Build up valve assembly by installing all the fittings in the direction shown.
 - D. Attach new valve assembly to existing relay bracket (Item 3) and existing ABS brake valves mounting bracket (Item 1) with three (3) 5/16 nuts BB # 0829390.
 - E. Install ½” pipe bushings (Item 8) into Delivery Port of right hand ABS Modulator. Attach a new 20 inch long hose (Item 9) from right hand ABS modulator to right hand brake chamber service port. Install ½” pipe bushings (Item 8) into Delivery Port of left hand ABS Modulator. Attach a new 20 inch long hose (Item 9) from left hand ABS modulator to left hand brake chamber service port.
 - F. Reconnect the right hand modulator wiring harness.
 - G. Connect new harness extension BB # 0034459 to the existing wiring harness and the left hand modulator.
 - H. If the entire brake assembly was removed (See Note1 in Step 4A), re-install after the R12DC valve and fitting have been installed.
 - I. Connect all the airlines per Illustration 2.
6. Route 3/8 OD Brown air brake tubing BB # 0012435 (Item 25) from the R12DC brake valve to the secondary port on the brake treadle valve. See Illustration 3 for port locations on R12DC valve and brake treadle valve. This MUST be routed with existing tubing on the chassis. THE FOLLOWING ARE TIPS TO AID IN THIS ROUTING.
- A. Under driver’s area, remove the horn attaching bracket to provide access to treadle valve. Also, lower and remove spare tire (if so equipped) to provide access to tubing on inside of frame rail.
 - B. Disconnect ½” red tubing (Delivery Port 22 on treadle valve), and remove existing 90 degree elbow and discard.

Note: 90 degree fitting in Delivery 21 will need to be turned to allow 90 degree elbow to be removed from Delivery 22. In Delivery Port 22, install a brass street tee BB # 0016750 (Item 29) as shown. Install a 90 degree elbow BB # 0009960 (Item 28) into end as shown. Reconnect existing ½” red tubing. Install a male connector BB # 0009918 (Item 30) into the bottom of street tee for new secondary line (3/8 Brown Tubing). Turn elbow in Delivery 21 back to the original location.

- C. The center luggage compartment-ceiling panel has a break from front to rear. Locate new closeout panel to left side of center break. Use the new closeout panel provided BB # 0034460 as a marking template to mark the outside of the panel and the hole locations for attaching the panel in a later step. Cut a hole in the existing luggage panel for access to the air brake tubing inside the chassis frame. Note leave at least ½ of metal between new holes and cutout. Also, be careful not to cut or damage existing wiring and other tubing.
 - D. Cover the end of the air brake hose to keep the inside of the air brake tubing clean from all contamination during routing process. NOTE: Remove cover from tubing before connecting to valve.
 - E. Route Brown air brake tubing BB # 0012435 (Item 25) inside the frame rail channel and inside existing clamps from R12DC valve at drive axle to treadle valve at front of vehicle. Connect Brown tubing to 90 degree elbow BB # 0009914 (Item 20) at R12DC to male connector BB # 0009918 (Item 30) at treadle valve.
 - F. Using the closeout panel as a guide, drill 0.203 diameter holes. NOTE: DO NOT DRILL INTO ANY WIRING HARNESS OR TUBING.
 - G. Apply gray sealant BB # 3809639 around cutout in luggage compartment ceiling and holes.
 - H. Attach panel with 3/16 pop rivets BB # 1415769 (18 required).
7. Re-install horn bracket (removed in step 6A). If a spare tire was removed, re-install tire. Build the air brake system to maximum air pressure. Check for air leaks.

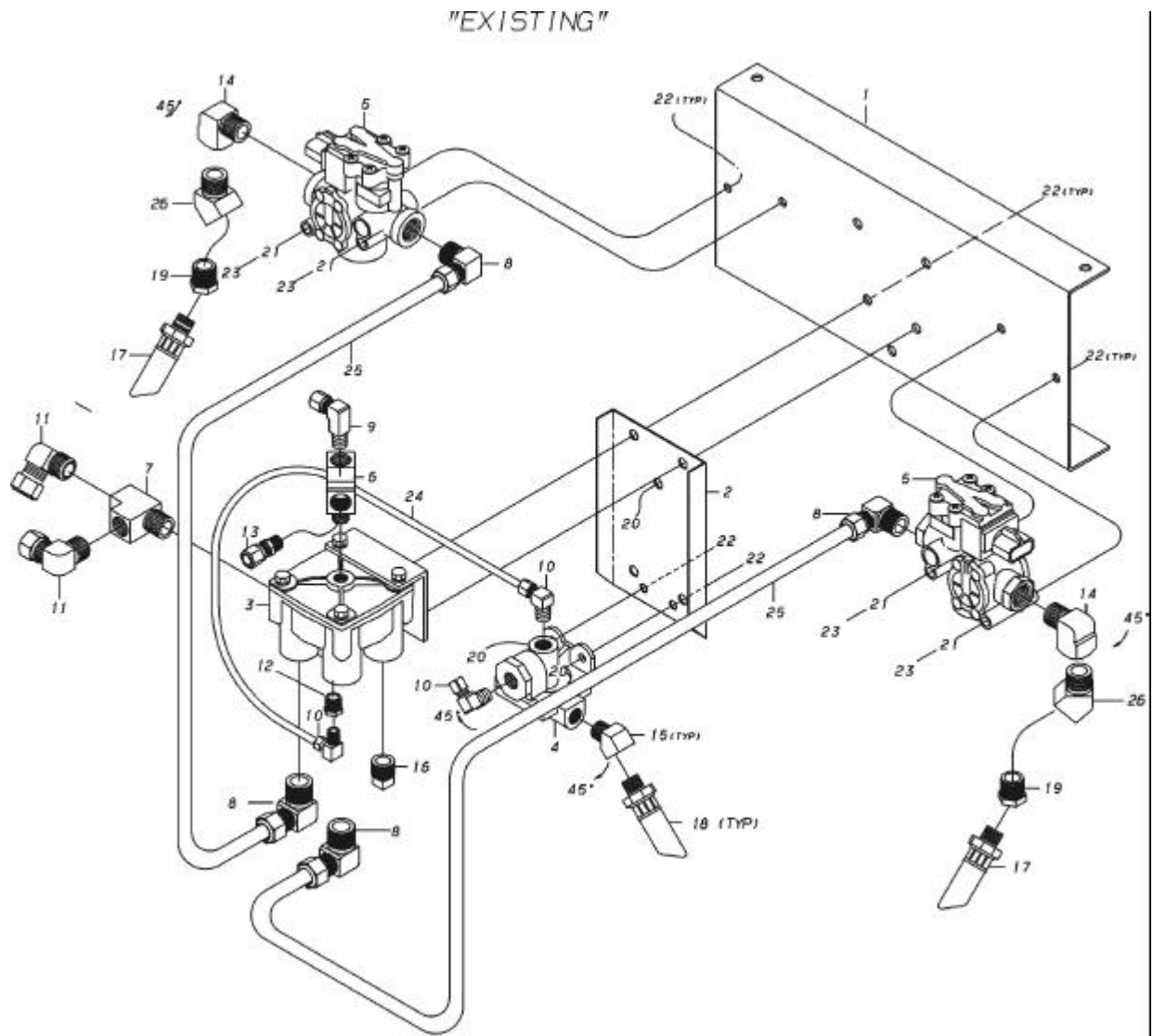

ILLUSTRATION 1

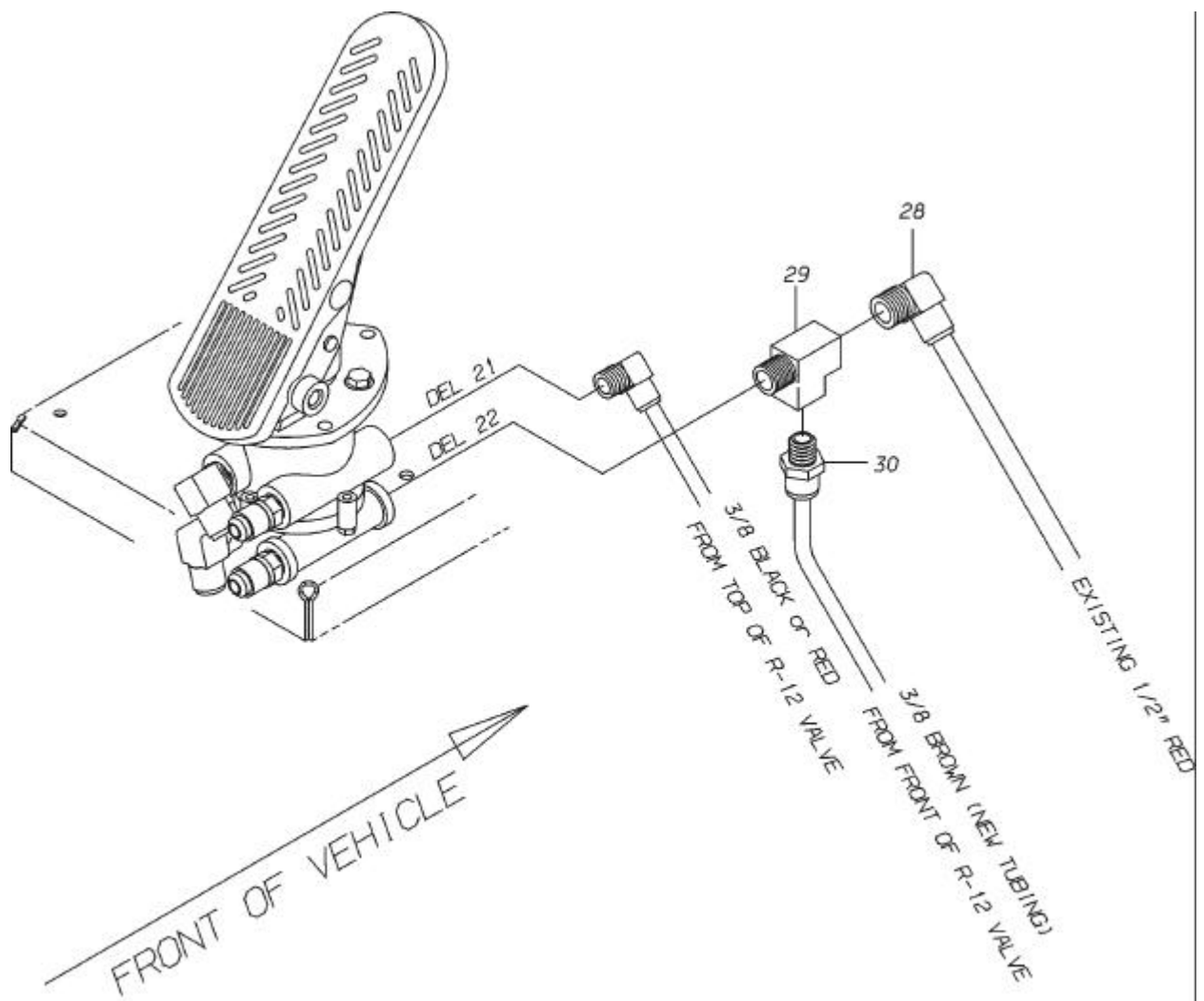

ILLUSTRATION 3

Parts List:

Item Number	Qty	Part Number	Description
1	1	0009906	Elbow, 90 Deg, Male 1869 x 8-Z, .38 MPT X .50T
2	2	0009907	Elbow, 90 Deg, Male 1869 x 8 x 8-Z, .50 MPT X .50T
3	2	0009908	Elbow, 90 Deg, Male 1869 x 10-Z, .50 MPT X .63T
4	1	0009911	Elbow, 90 Deg, Male 1869 x 6 x 6-Z, .38 MPT X .38T
5	1	0009913	Elbow, 90 Deg, Male 1869 x 4 x 6-Z, .38 MPT X .25T
6	1	0009914	Elbow, 90 Deg, Male 1869 x 6-Z, .25 MPT X .38T
7	1	0009918	Connector, Male, 1868 x 6x 6-Z .38MPT x .38T
8	2	0009921	Connector, Male, 1868 x 8-Z .38MPT x .50T
9	1	0011946	Elbow, 45 Deg, Male 1880 x 6-Z, .25 MPT X .38T
10	40'	0012435	Tubing, Plastic, 3/8 OD, Brown, SAE J844 Type B
11	1	0016750	Tee, Brass, 3/8 MPT x 3/8 FPT X 3/8 FPT, 3600 x 6
12	2	0031446	Bracket, Mounting, Modulator, ABS, LTC, Retro
13	1	0034459	Harness, Wiring, Extension, LTC, ABS Modification, 12" Service
14	1	0034460	Panel, Closeout, Luggage, LTC Rework, Service
15	1	0654350	Tee, Street, 1/2 Pipe
16	1	0663427	Plug, 1/2 Square Head, Pipe, 3151 x 8-Z, Brass
17	2	0770883	Hose Assembly, Brake, 7/16 X 20" Long
18	13	0829390	Nut, Hex Head, 5/16-18, Serrated Washer
19	7	0854414	Capscrew, Hex Head, 5/16 x 7/8 Grade 8 Yel ZN Dich.
20	4	1226877	Capscrew, Hex Head, 5/16 X 3 1/2, Grade 8, Yel, ZN Dich.
21	20	1415769	Rivet, Pop, .18 x .45 Cherry SSPS-6-4
22	1	1995851	Valve, Relay, R12, with Double Check, ABS
23	8	2001048	Washer, Flat, 11/32 x 11/16 x 1/16, Yel, Zn Dich.
24	2	2023539	Bushing, Pipe, 1/2 MPT X 3/8 FPT, 3220 x 8 x 6-Z
25	1	3809639	Sealant, Sikaflex, 221, Gray (tube0