

R02GD

July 24, 2002

Dear Blue Bird Owner:

This notice is sent to you in accordance with the requirements of the National Traffic and Motor Vehicle Safety Act. Blue Bird Body Company has determined that a defect, which relates to motor vehicle safety, exist in certain 1999 through 2002 year model Blue Bird LTC 40 tour type coaches. Blue Bird is conducting a recall to correct this defect.

The defect involves the manner in which the overhead parcel racks are attached to the ceiling on subject coaches. Irregularities in installation procedures have been found in the installation of the fasteners, which may allow the parcel racks to loosen and fall without warning.

Blue Bird Body Company's evaluation of the risk to motor vehicle safety reasonably related to this defect is the potential for injury to passengers in the event the fasteners become dislodged and the racks should fall while passenger seats are occupied.

Your Blue Bird coach (es) affected by recall R02GD are identified by body serial number(s) on the enclosed reply sheets. If you no longer own the subject coach (es), please complete the appropriate section of the yellow reply sheet and return to Blue Bird in the enclosed pink postage prepaid envelope.

You must perform the interim repair immediately. Parts and instructions for the interim repair are being shipped to you via UPS "Next Day" delivery. A copy of this notification letter will be included with the interim parts and instructions. If you do not receive the interim parts, please contact me at 478-822-2242.

A final modification kit with instructions will be forwarded to you "No Charge" via UPS regular delivery as soon as parts are available.

Time required to perform the interim repair is one (1) hour per coach. Time required to perform final modification is 40 hours per coach.

R02GD

Page 2

You may perform this modification yourself or have the work done by a qualified repair facility convenient to you. You may contact your Blue Bird distributor for assistance.

Upon completion of the recall, the owner should complete and return the pink reply sheet in the postage prepaid envelope provided. The owner may request reimbursement of labor costs by completing the appropriate section of the pink reply sheet. If repair is performed by other than the owner or a Blue Bird distributor, attach a copy of the paid work order/invoice to the reply sheet.

Important: Your prompt return of the pink reimbursement sheet, complete with the correct Body Serial Numbers, permits Blue Bird to update the record indicating recall has been completed and prevents the mailing of a second notice. This is much appreciated. We regret any inconvenience this may have caused.

If Blue Bird Body Company should fail to or is unable to remedy this condition without charge to you, you may contact:

**ADMINISTRATOR
NATIONAL HIGHWAY TRAFFIC SAFETY ADMINISTRATION
WASHINGTON, D.C. 20590**

or you may call The National Highway Traffic Safety Administration toll free at:

1-888-327-4236

Questions regarding this recall campaign should be directed to me at (478) 822-2242.

Thank you,

Bill Coleman
Recall Administrator

BLUE BIRD BODY COMPANY

RECALL R02GD PARCEL RACK SECUREMENT INTERIM MODIFICATION

Use the following procedures to install four (4) parcel rack support bolts:

1. Park the coach on a level surface and remove the ignition key.
2. With a small stepladder or step stool in the center aisle, open the roof hatch for access to top of coach.
3. NOTE: The 6 1/4" dimension was taken on several coaches at Blue Bird. However, some roof hatches may be located differently. To confirm that this dimension is correct, open the roof hatch and locate two rows of rivets before and aft of roof hatch. Measure from rivet to rivet and mark the center point between these rivets. Measure from inside of roof hatch to the mark between the two rows of rivets. If this matches the 6 1/4", then use the 6 1/4", if not, use the new measurement in lieu of the 6 1/4".
4. Locate the centerline of the roof bow forward of the front roof hatch by measuring 6 1/4" from the inside of the front hatch forward. See Figure 1. Now locate the intersection of this roof bow with the outside aisle support for the parcel rack on both the right and left side of the coach. Mark this intersection.

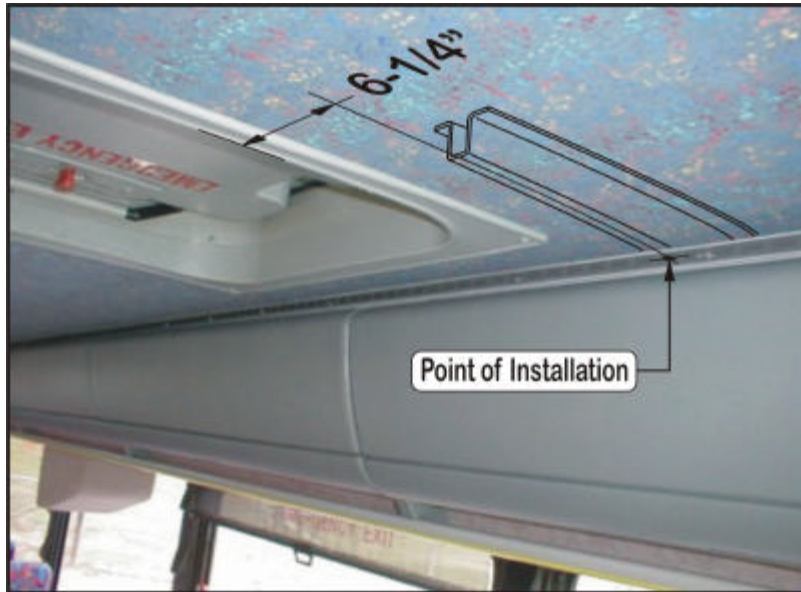

Figure 1

5. Open the parcel rack doors to gain access to installation points on each side.
6. Remove the light panels and lay aside.

RECALL R02GD PARCEL RACK SECUREMENT INTERIM MODIFICATION

Page 2

7. If there is an existing fastener, remove fastener. Drill a 13/32-diameter hole through the parcel rack support. Hold the drill perpendicular to the inside headlining panel, continue drilling through the outside of the roof sheet. If there is no existing fastener in this location, drill a 13/32-diameter hole through center of the lower flange of the extrusion, through the upper flange of the extrusion (against headlining). Hold the drill perpendicular to the inside headlining panel, continue drilling through the outside of the roof sheet.
8. Review the hole on top of the coach and remove any burrs.
9. Apply sealer around the hole on the roof to cover washer when installed.
10. Place the two (2) large stainless steel washers onto the 3/8" bolt and insert bolt through hole from the outside. On the inside, install two (2) small washers and the 3/8" locknut. Tighten the locknut until a minimum of 2 complete threads is through the lock nut. Install the bolt on the opposite side.
11. Close the doors to locate rear holes.

Note: Refer to instruction in "Note" on page one for locating dimension.

12. Locate the centerline of the roof bow rearward of the front roof hatch by measuring 6 1/4" from the inside of the front hatch rearward. See Figure 1 on page 1. Now locate the intersection of this roof bow with the outside aisle support for the parcel rack on both the right and left side of the coach. Mark this intersection.
13. Open the parcel rack doors to gain access to installation points on each side.
14. If there is an existing fastener, remove fastener. Drill a 13/32-diameter hole through the parcel rack support. Hold the drill perpendicular to the inside headlining panel, continue drilling through the outside of the roof sheet. If there is no existing fastener in this location, drill a 13/32-diameter hole through center of the lower flange of the extrusion, through the upper flange of the extrusion (against headlining). Hold the drill perpendicular to the inside headlining panel, continue drilling through the outside of the roof sheet.
15. Review the hole on top of the coach and remove any burrs.
16. Apply sealer around the hole on the roof to cover washer when installed.

RECALL R02GD PARCEL RACK SECUREMENT INTERIM MODIFICATION
Page 3

17. Place the two (2) large stainless steel washers onto the 3/8” bolt and insert bolt through hole from the outside. On the inside, install two (2) small washers and the 3/8” locknut. Tighten the locknut until a minimum of 2 complete threads is through the lock nut. Install the bolt on the opposite side

18. Reinstall the light panels.

19. Close doors and roof hatch.

Parts List:

Each Interim parts kit contains the following parts to secure the parcel racks to the second and third bows on each side of the coach. Be sure to read instructions thoroughly before beginning work.

Qty	Part Number	Description
4	0055807	Capscrew, Hex, 3/8-24 X 3 1/2, Stainless
4	0055834	Locknut, Hex, 3/8-24 L/N 18-8, Stainless
8	3748688	Washer, flat, Type B, Regular, 3/8 Stainless
8	1107085	Washer, Flat, 13/32 X 13/16
1	3820495	Sealant, Silkaflex, 221 White, Ind
1	NPN	Interim Parts Installation Instructions

RECALL R02GD
PARCEL RACK SECUREMENT FINAL MODIFICATION INSTRUCTIONS

1. Above the window close out, remove the screws and/or rivets from the parcel rack assembly first.
2. Remove the video system from the parcel racks.
3. Remove the lights inside the parcel rack.
4. Label & mark all wires after removing end cap.
5. Remove Parcel racks.
6. If interim modification had been performed on coach, remove and discard all fastener components used in interim modification.

If interim modification has not been performed, use the following instructions for locating the first two bows.

- A. With a small stepladder or step stool in the center aisle, open the roof hatch for access to top of coach.
- B. NOTE: The 6 ¼" dimension was takes on several coaches at Blue Bird. However, some roof hatches may be located differently. To confirm that this dimension is correct, open the roof hatch and locate two rows of rivets before and aft of roof hatch. Measure from rivet to rivet and mark the center point between these rivets. Measure from inside of roof hatch to the mark between the two rows of rivets. If this matches the 6 ¼", then use the 6 ¼", if not, use the new measurement in lieu of the 6 ¼".
- C. Locate the centerline of the roof bow forward of the front roof hatch by measuring 6 ¼" from the inside of the front hatch forward. See Figure 1. Now locate the intersection of this roof bow with the outside aisle support for the parcel rack on both the right and left side of the coach. Mark this intersection and continue to rear extrusion (inside hanger).

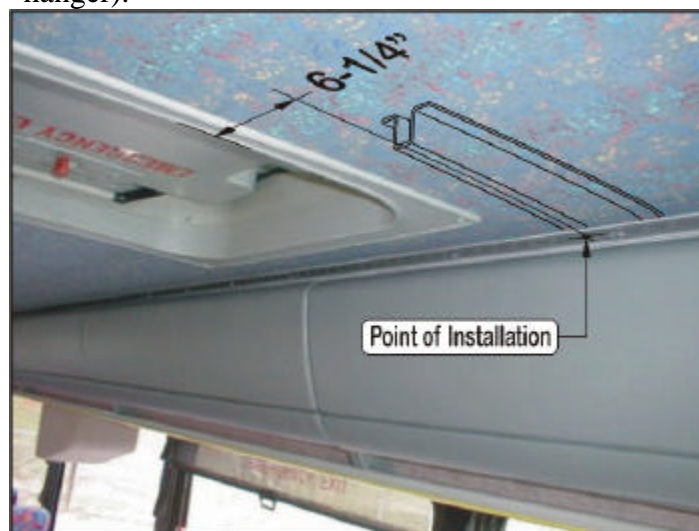

Figure 1

NOTE: Figure 1 shows how to locate bow with parcel rack installed. Continue on same centerline outward for rear extrusion (Inside Hanger)

CAUTION: A Fall Protection System designed for support of an individual should be used when working on top of coach because of smooth and sloping surfaces. DO NOT work on top of a coach when the coach is wet or is snow covered.

7. On rear extrusion (inside hanger) if there is an existing fastener, remove fastener. Drill a 13/32"-diameter hole through the rear extrusion flange. Hold the drill perpendicular to the inside headlining panel, continue drilling through the outside of the roof sheet.

If there is no existing fastener in this location, drill a 13/32" –diameter hole through center of the flange of the extrusion (against headlining). Hold the drill perpendicular to the inside headlining panel, continue drilling through the outside of the roof sheet.

NOTES:

- A. If rear extrusion (inside hanger) does not attach to at least two roof bows, rear extrusion (inside hanger) **MUST** be replaced with an extrusion that attaches to a minimum of two bows.
 - B. If the rear extrusion (inside hanger) has existing fasteners between the bows, remove only the fasteners at the bow. Do not remove fasteners between the bows.
8. Review the hole on top of the coach and remove any burrs.
 9. Apply sealer around the hole on the roof to cover entire washer when installed.
 10. Place the two (2) large stainless steel washers onto the 3/8"-24x3" bolt and insert bolt through hole from the outside. On the inside, install one (1) or two (2) small washers as required and the 3/8" locknut. Tighten the locknut until a minimum of 2 complete threads is through the lock nut. Install the bolt on the opposite rear extrusion (inside hangers).

Notes: 1. Anti-seize compound should be used with 3/8" bolt and nut installation.

2. BOLTS **MUST** BE INSTALL IN BOWS, DO NOT INSTALL IN ANY OTHER LOCATION.

Note: Refer to instruction in "NOTE" on page 1 for locating dimension.

11. Locate the centerline of the roof bow rearward of the front roof hatch by measuring 6 ¼" from the inside of the front hatch rearward. (Front Extrusion-- See Figure 1) Now locate the intersection of this roof bow with the (outside aisle support) for the parcel rack on both the right and left side of the coach. Mark this intersection and continue to rear extrusion (inside hanger). After locating, follow above steps 7, 8, 9 and 10 above.
12. Using the first two bows on the outside roof as a beginning point, measure and record the center of the remaining bows from the front to rear of coach. Using these measurements, measure & mark the center of each bow on the inside of the coach.
13. Drill holes at each rear extrusion (inside hanger) location following step # 7 and follow steps 8, 9 and 10 above for fastener installation.
14. On 2000 through 2002 fasten end of parcel rack not on the bow with 5/16" screws, spaced 6.0" apart from last 3/8" cap screw to the ends of the parcel rack. Note: The left front behind driver and the right rear in front of restroom is standard location that will require these fasteners. However, if another location exists, please add as required.
15. On 1999 parcel racks you can fasten end of parcel rack every 3.0" with 5/16 screws. The left front behind driver and the right rear in front of restroom is standard location that will require these fasteners. However, if another location exists, please add as required.
16. Install the 5/16 screw in the holes in the front extrusion front to rear where the rivets were removed.

NOTE: Use Blue Loctite on screws.

17. Using the compression marks for the front extrusion (aisle side) as a guide, place a 2" x 2" piece of masking tape at location of front extrusion & roof bow.
18. If the interim modification had been completed earlier, use the holes for the front two bows as a guide for measuring & marking the remaining hole location. If the interim modification had not been performed, follow step 6 to locate first two holes on each side. Using the measurement taken in step 12, mark the center of each roof bow for front extrusion (aisle side).

19. On units with headlining and board material underneath the front extrusion (aisle side), a ¼ “ thick spacer is required. Using a 1” hole saw, at each front extrusion & bow location, drill a clearance hole to remove the headlining & board material. **DO NOT drill through sheet metal or roof bow.**

20. Inspect the parcel rack molded support arm rear hook for cracks or damage. If any part of the arm including the hook is cracked, broken or damaged, the entire arm must be replaced.

21. Hang the parcel rack from the rear extrusion (inside hanger) and support.

Note: Supports may be large wooden or steel supports with protective covering on ends to prevent damage to interior parts.

22. Following step 7 above drill up through the roof at each bow location centering on the clearance hole.

Notes: 1. Remove parcel rack doors as necessary for access to front extrusion (aisle side).
2. If you cannot drill a hole through the bow because door lever is in the way omit this step at this time.

23. Using the new rows of drilled holes on top of coach, chalk or draw a line from hole to hole front to rear across bows that do not have holes from step 22 above.

24. Mark center of bow (between two rows of rivets that are approximately 2 1/8” apart).

25. Drill any holes omitted in step 22 at this time from the topside of the coach down through the coach roof.

26. Review the hole on top of the coach and remove any burrs.

27. Apply sealer around the hole on the roof to cover entire washer when installed.

28. Place two (2) large stainless steel washers onto a 3/8"-24 x 3 ½” long bolt and insert through hole from outside. Lower parcel rack enough to place ¾ spacer inside clearance hole between metal roof sheet & front extrusion upper flange. Push bolt through spacer & through front extrusion upper flange. Install one (1) or two (2) small washers & the 3/8” locknut. Lower flange may require notching for clearance for locknut. Tighten the locknut until a minimum of 2 complete threads will be through locknut.

Note: Anti-seize compound may be used with 3/8” bolt installation.

29. Repeat step 28 until all the 3/8" fasteners have been installed. Then remove the excess sealant from the outside washers and bolts. **BOLTS MUST BE INSTALL IN BOWS, DO NOT INSTALL IN ANY OTHER LOCATION.**
30. Reinstall the end caps and the video system.
31. Reinstall the lights inside the parcel racks.
Note: Bolts may have to be cut to install lights.
32. Reinstall the parcel rack doors.
33. Reinstall the insulation for the ducts and installed the fasteners removed in step 1.
Note: Blue Loctite may be used to prevent screws from loosening.

PARTS LIST

ITEM #	PART NUMBER	DESCRIPTION	QUANTITY
1	0055807	Bolt, Hex Head, 3/8-24 x 3 1/2 stainless steel	25
2	0056639	Bolt, Hex Head, 3/8-24 x 3" stainless steel	25
3	0056027	Washer, 3/8 x 2.0 stainless steel	80
4	0055834	Locknut, 3/8-24, stainless steel	50
5	0055804	Spacer, .75 OD x .437 ID x .25 thick, black	20
6	3748688	Washer, 3/8 stainless steel	80
7	2000198	Screw, 5/16-18 x 1.0, Hex Head	100
8	3820495	Sealant, Silkaflex, 221 white	2 Tubes

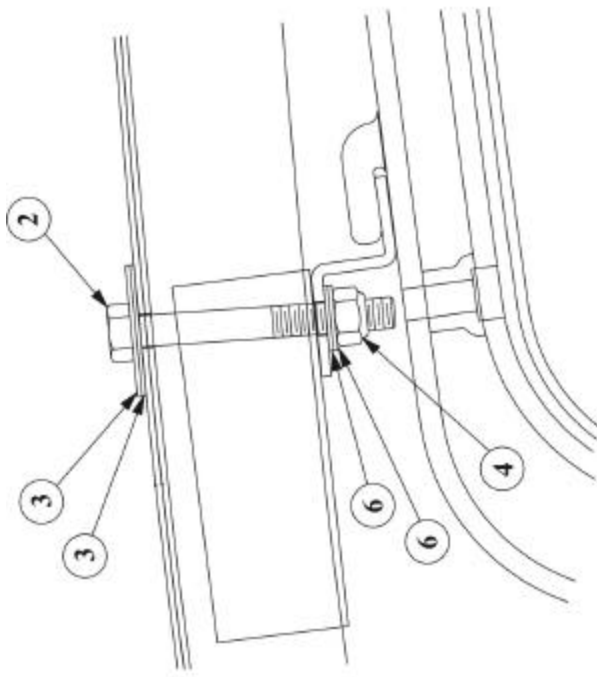

DETAIL B

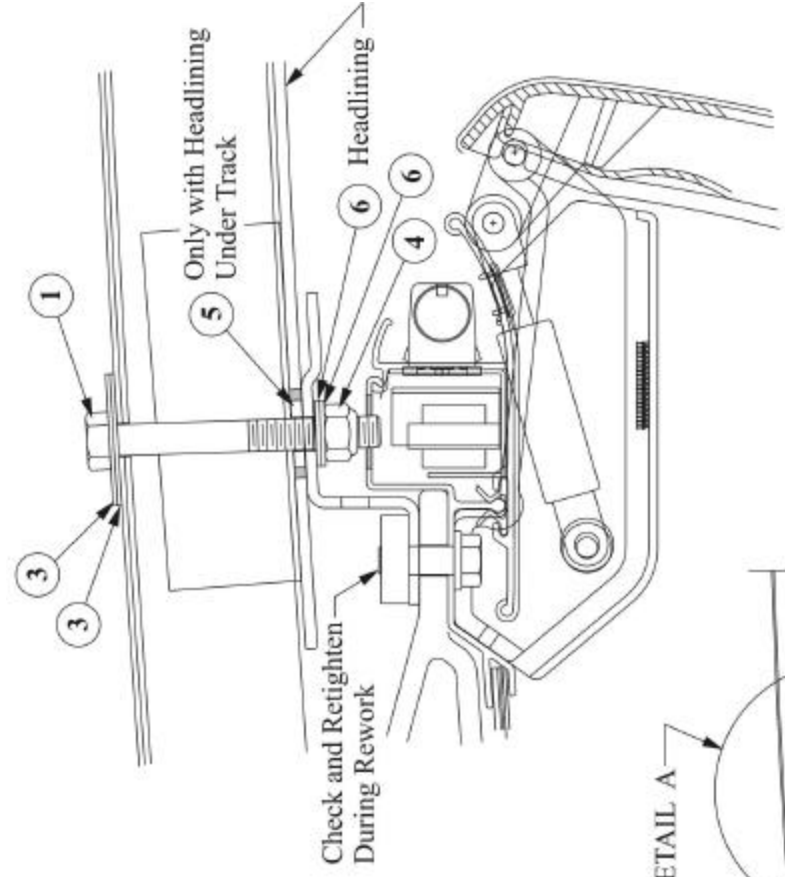

DETAIL A

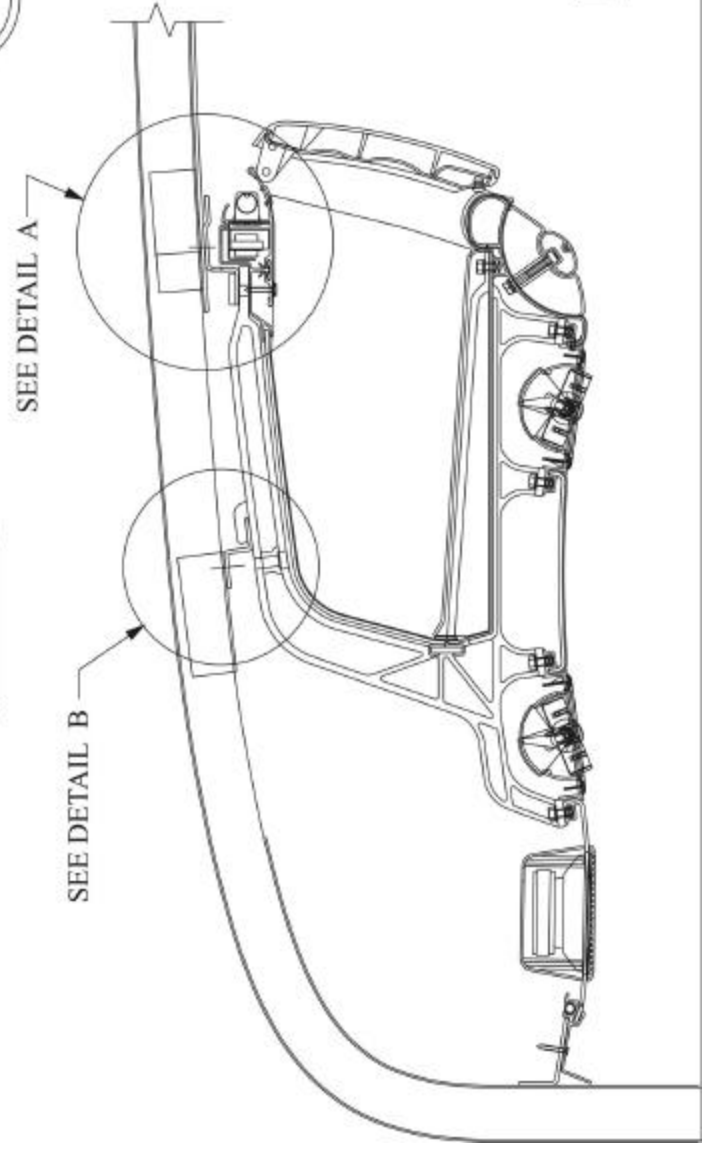

**1999 & 2000
MODEL COACHES**

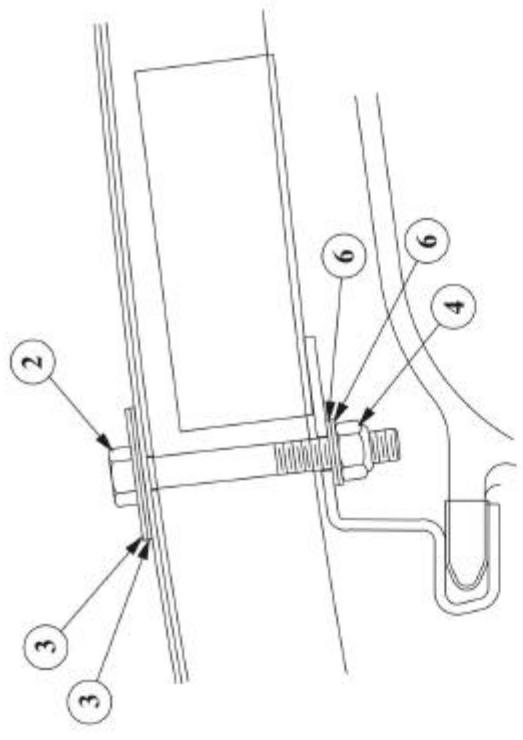
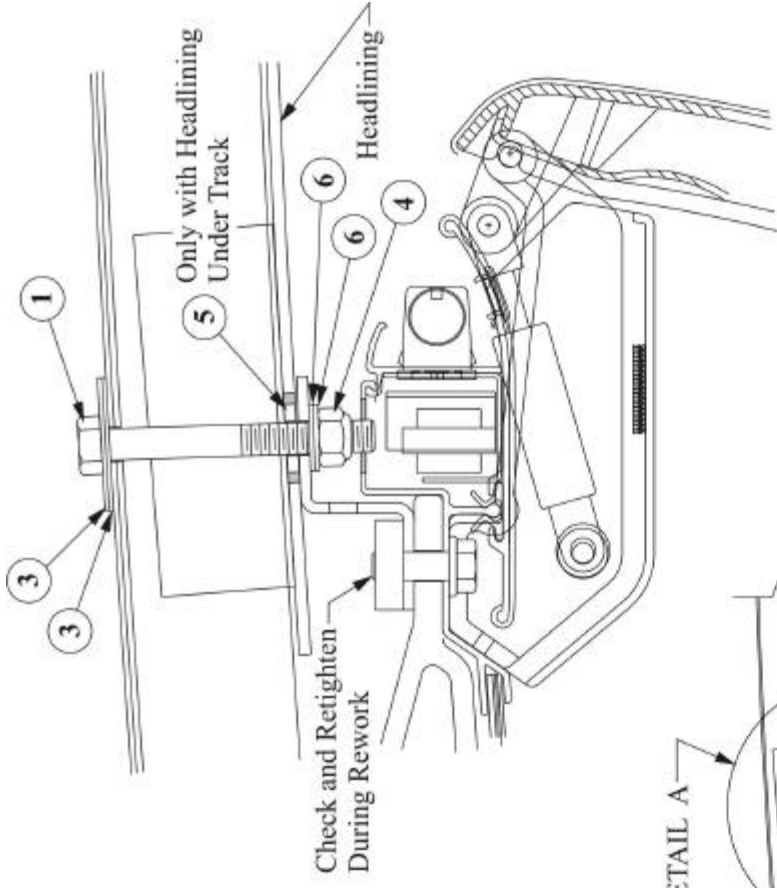

DETAIL B

DETAIL A

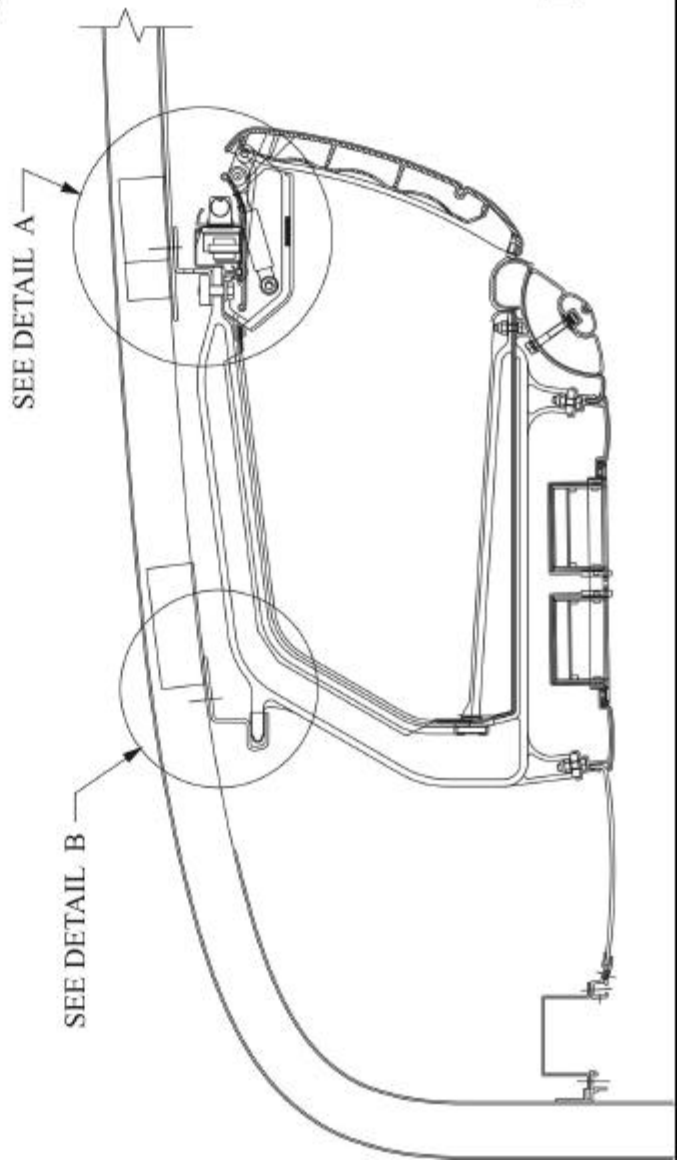

**2001 & 2002
MODEL COACHES**