

R03HC

November 20, 2003

Dear Blue Bird Owner:

This notice is sent to you in accordance with the requirements of the National Traffic and Motor Vehicle Safety Act.

Blue Bird Body Company has decided that a defect which relates to motor vehicle safety exists in certain 2003 through 2004 model year Blue Bird All American (A3RE) rear engine model school buses manufactured at the Lafayette, Georgia plant. Subject buses are equipped with optional seat belts. Blue Bird Corporation is conducting a recall to correct this defect.

The defect involves the spacing and location of bolts used to anchor the davenport seat belts.

Blue Bird Corporation's evaluation of the risk to motor vehicle safety is that in the event of a severe crash, subject seat belts could detach from the davenport attachment points which could increase the risk of personal injury or death to passengers.

Your Blue Bird bus(es) affected by recall R03HC are identified by body serial number(s) on the enclosed reply sheets. **You should have this condition corrected immediately.**

Federal law requires that any vehicle lessor receiving this recall notice must forward a copy of this notice to the lessee within ten days.

If you no longer own the subject bus(es), please complete the appropriate section of the **yellow** reply sheet and return to Blue Bird in the enclosed **pink** postage prepaid envelope.

To receive parts required to complete this recall, confirm your proper shipping address, sign and return the enclosed **yellow** parts request sheet and return it to Blue Bird in the enclosed **pink** postage prepaid reply envelope. Replacement parts will be shipped to you "No Charge" via UPS.

A qualified technician should perform this modification or you may contact your Blue Bird distributor for assistance.

Time required to perform recall R03HC is three (3) hours per bus.

Reimbursement for labor may be obtained by completing the **pink** request for reimbursement sheet provided and returning it to Blue Bird in the enclosed **pink** postage prepaid envelope.

If the modifications/repair directed by this modification was performed on your bus prior to the receipt of this recall notification, complete and sign the **pink** recall reply sheet and attach a copy of the work order/invoice. Mail the documents in the self-addressed postage paid **pink** envelope included with the recall notification to Blue Bird for warranty consideration. Reimbursements will be made in accordance with the requirements of the National Highway Transportation Safety Act, title 49 Code of Federal Regulations, Parts 573 and 577.

Important: Your prompt return of the **pink** reimbursement sheet, complete with the correct Body Serial Numbers, permits Blue Bird to update the record indicating recall has been completed and prevents the mailing of a second notice. This is much appreciated. We regret any inconvenience this may have caused.

If Blue Bird Body Company should fail to or is unable to remedy this condition without charge to you, you may contact:

**ADMINISTRATOR
NATIONAL HIGHWAY TRAFFIC SAFETY ADMINISTRATION
WASHINGTON, D.C. 20590**

or you may call The National Highway Traffic Safety Administration toll free at:

1-888-327-4236

Questions regarding this recall campaign should be directed to me at (478) 822-2242.

Thank you,

Bill Coleman
Recall Administrator
BLUE BIRD BODY COMPANY



Davenport Seat Belt Anchorage

MODELS AFFECTED: 2004 Blue Bird All American Rear Engines (A3RE) with Seat Belts

RECALL CAMPAIGN R03HC

ISSUE

The spacing and location of the davenport seat belt anchoring bolts are not within specified parameters. In addition, incorrect bolts, washers and nuts may have been installed.

CORRECTIVE ACTION

Remove original davenport seat belt anchoring bolts. Drill new holes at the correct location and install correct bolts, washers and nuts.

It may be possible for some buses to have correct spacing and bolt size. Inspect the bus according to the procedures outlined below.

PROCEDURE

- 1** Park the bus on a level surface and apply the parking brake. Remove the key and chock the wheels. Disconnect the battery cables.
- 2** Open the engine compartment, allow the engine ample time to cool to ambient temperature.
- 3** Inspect the seat belt anchorage bolts protruding from the rear davenport wall. If the fasteners appear as shown in Figures 1 or 2 **STOP**. These installations are acceptable.



Figure 1

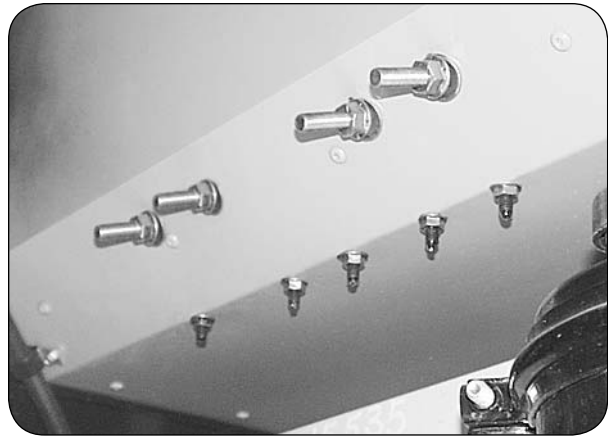

Figure 2

If the seat belt anchorage bolts are installed as shown in Figure 3, proceed to Step 4.



Figure 3

4 Remove screws that secure both davenport seat backs to the rear engine compartment upper deck. Lift and remove the seat backs.

5 Compress the rear of the davenport seat cushion and remove the screws that secure the seat cushions to the inner rear davenport panel.

6 Remove screws that secure the front edge of the davenport seat cushions. Lift and remove the seat cushions.

7 Remove and retain all seat belt assemblies with mounting brackets from the davenport seat deck.

8 Reinstall the old bolts, washers and nuts into their original locations and torque to 15 ft. lbs.

6 Using the hole pattern diagram that coincides with your seat size, drill 15/32 inch (.468) diameter holes through the rear davenport panel 7/8 inch (.88) above davenport seat deck. Maintain the drill at a 90 degree angle to the rear davenport seat panel. See "Hole Pattern Diagram" on page 3.

7 Inspect the bracket and seat belt assemblies, if damage to the bracket exist, please contact Bill Coleman at Blue Bird Body Company; Phone 478.822.2242.

8 Install bracket with seat belt in new position as shown in "Seat Belt Bracket Installation" on page 3. Install new 7/16 - 20 x 2.25 inch bolt (BB #0067476), two flat washers (BB #2028546) and flanged nut (BB #0060652). Bolts must be torqued to 30-33 ft. lbs.

Note: When torquing bolts during installation, panel compression may occur along the top edge of the nut and washer. At the same time, a gap may be noticed at the lower edge of the nut and/or washer. This condition is acceptable.

9 Clean the area of all metal shavings. Reinstall davenport seat cushions and backs by reversing the procedure of steps four through six.

10 Close engine compartment door, reconnect battery cables and remove wheel chocks before moving vehicle.

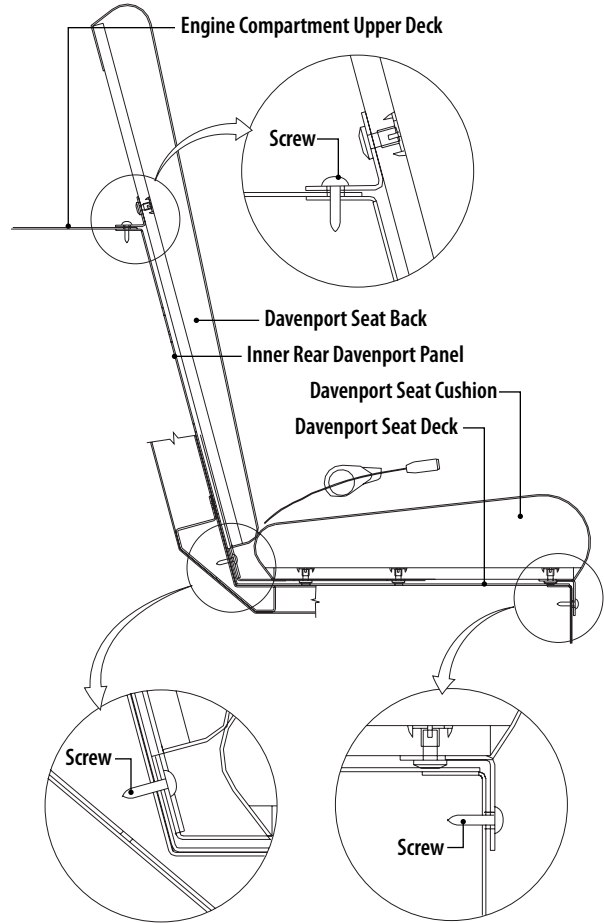

Steps Four Through Six

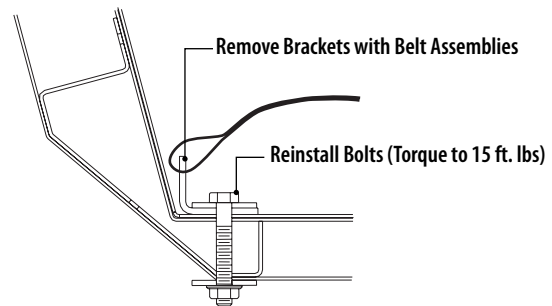

Steps Seven & Eight

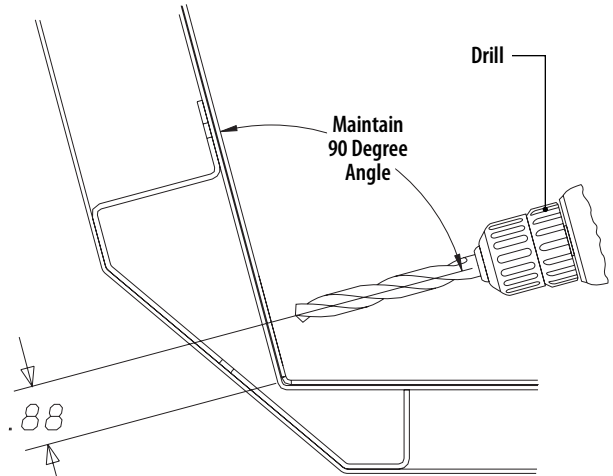
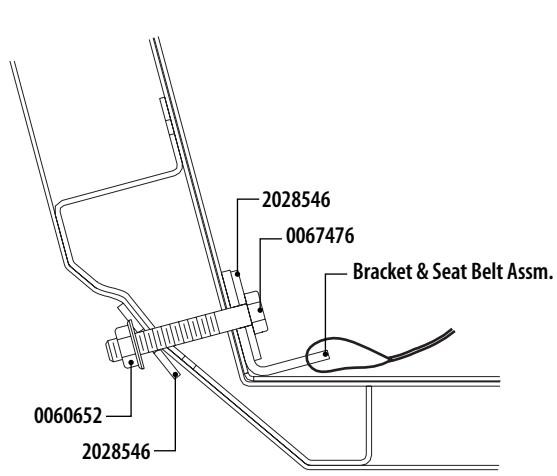
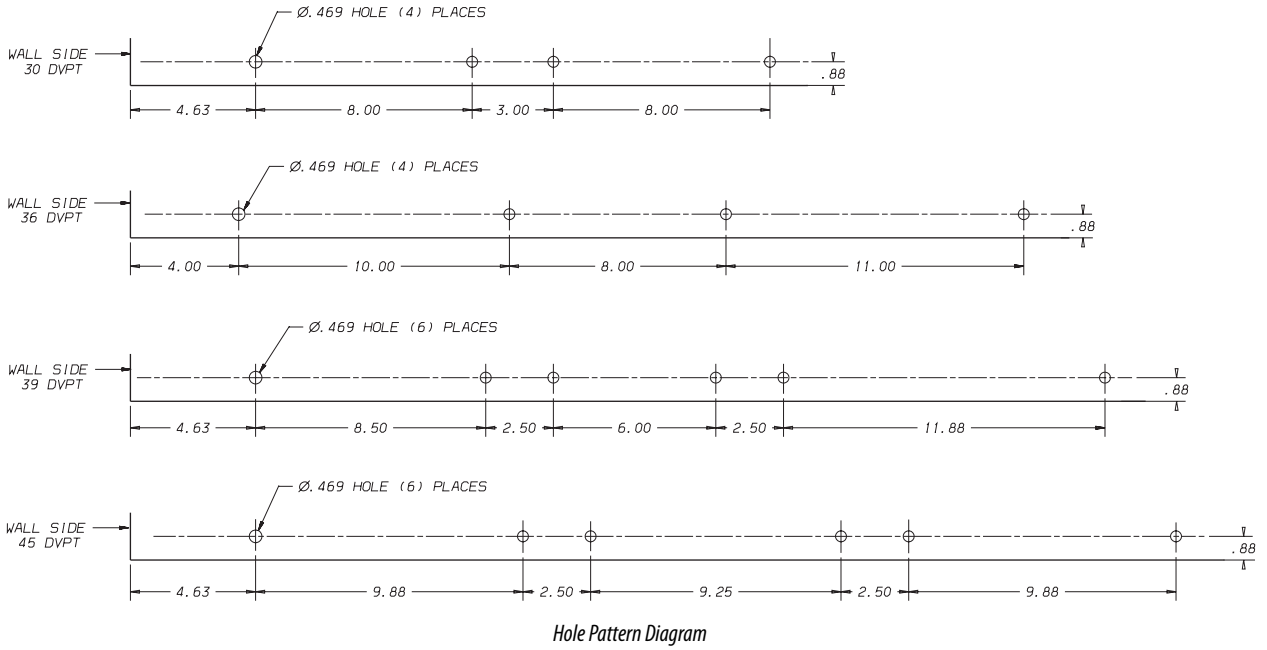

PARTS LIST

Part Number	Description	Qty.	Qty.	Qty.	Qty.
		30" Seat	36" Seat	39" Seat	45" Seat
0067476	Bolt, 7/16 -20 x 2.25, Grd 8, Zn	8	8	12	12
2028546	Flat Washer, 7/16 x 1 1/32 x 5/64, Yel Zn	16	16	24	24
0060652	Flange Nut, 7/16 - 20, Grd 8, Yel Zn Dich	8	8	12	12