

R04HT

June 08, 2004

Dear Blue Bird Owner:

This notice is sent to you in accordance with the requirements of the National Traffic and Motor Vehicle Safety Act.

Blue Bird Body Company has decided that a defect which relates to motor vehicle safety exist in certain 2004 and 2005 model year Blue Bird All American front engine school and transit buses equipped with Option 2836-01 Driver's 3-Point Seat Belt. The subject buses were manufactured at Canadian Blue Bird in Brantford, Ontario from March 03, 2003 through April 05, 2004.

The defect involves the fasteners that retain the 3-point driver's seat belt shoulder strap upper attachment. Incorrect fasteners were originally installed. Blue Bird is conducting a recall to correct this defect.

Blue Bird Body Company's evaluation of the risk to motor vehicle safety reasonably related to this defect is in the event of a crash, the shoulder strap could fail, and the driver could be injured.

Special equipment is required to install the correct fasteners. Your Blue Bird distributor will contact you to schedule a time to perform Recall R04HT.

If you have a qualified technician and the special equipment necessary you may perform this recall. Please advise your distributor that you will be performing the modification. When modifications are completed reimbursement for labor may be obtained by completing the **pink** request for reimbursement sheet provided and returning it to Blue Bird in the enclosed pink postage prepaid envelope. Labor time required to perform Recall R04HT is 0.5 hours (30 minutes) per bus.

Your Blue Bird bus(es) affected by recall R04HT are identified by body serial number(s) on the enclosed reply sheets. If you no longer own the subject bus(es), please complete the appropriate section of the yellow reply sheet and return to Blue Bird in the enclosed pink postage prepaid envelope.

If the modifications/repair directed by this modification was performed on your bus prior to the receipt of this recall notification, complete and sign the recall reply sheet and attached a copy of the work order/invoice. Mail the documents in the **pink** self-addressed postage paid envelope included with the recall notification to Blue Bird for warranty consideration. Reimbursements will be made in accordance with the requirements of the National Highway Transportation Safety Act, title 49 Code of Federal Regulations, Parts 573 and 577.

Federal law requires that any vehicle lessor receiving this recall notice must forward a copy of this notice to the lessee within ten days.

If Blue Bird Body Company should fail to or is unable to remedy this condition without charge to you, you may contact:

**ADMINISTRATOR
NATIONAL HIGHWAY TRAFFIC SAFETY ADMINISTRATION
400 SEVENTH STREET, SW
WASHINGTON, D.C. 20590**

or you may call The National Highway Traffic Safety Administration toll free at:

1-888-327-4236

Questions regarding this recall campaign should be directed to me at (478) 822-2242.

Thank you,

Bill Coleman
Recall Administrator
BLUE BIRD BODY COMPANY



3-Point Seat Belt Fasteners

MODELS AFFECTED: 2004 & 2005 A3FE with Option 2836-01, Driver's 3-Point Seat Belt

RECALL

ISSUE

Incorrect fasteners may have been installed in upper mounting bracket of driver's shoulder belt height adjuster.

CORRECTIVE ACTION

Inspect the mounting bracket fasteners. If the incorrect fasteners are installed, replace with new correct fasteners.

PARTS

PART NUMBER	QUANTITY	DESCRIPTION
0041170	2	Fastener, Huck, 0.31, Blind
3853496	1 Tube	Adhesive, LOCTITE 242, 10 ML

PROCEDURE

1 Locate the 3-point driver's belt height adjuster mounting bracket assembly, behind the driver's window. The lower part of the bracket assembly attaches to the bow and the upper part to the headlining. The two upper holes of the bracket must be attached with a Huck rivet. If there are two Huck rivets installed, no further action is required. If one or two hex head screws have been installed, proceed to replacement procedures below.

2 Remove the seat belt height adjuster bolts, using a T50 Star Bit Socket/Torx Head Bit socket.

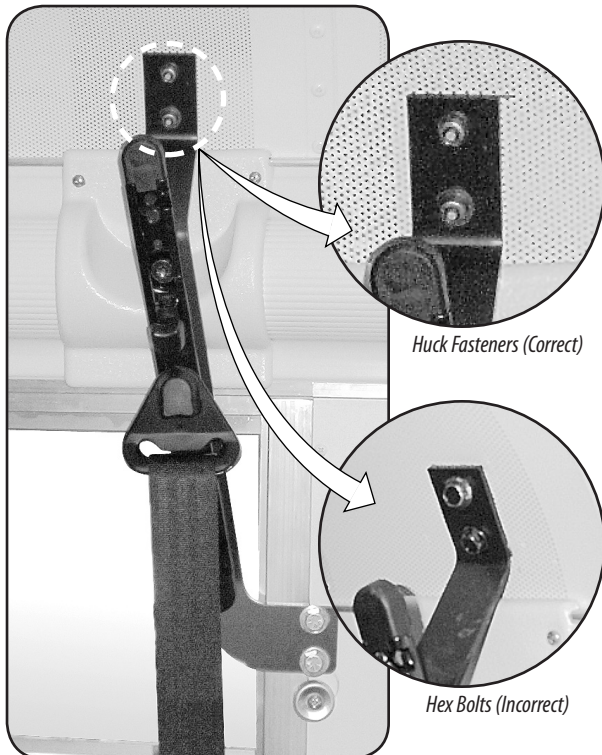

RO4HT

RECALL CAMPAIGN



RECALL

3 Remove one of the two upper mounting hex head screws.

4 Drill a 0.344 diameter hole using the 3- point driver's belt mounting bracket assembly as a guide. Drill through the 3- point driver's belt mounting bracket assembly, headlining and backing plate (behind headlining). Note: Use a short bit or a drill stop to prevent damage to outside roof.

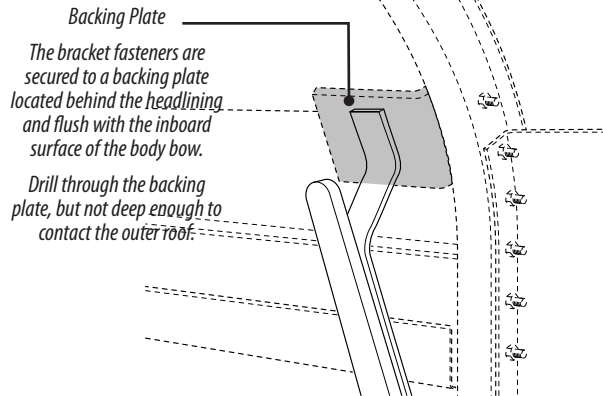

5 With Huck gun supplied by Blue Bird, install a 0.31 blind Huck fastener BB # 0041170 into 0.344 hole.



6 Remove second hex head screw and repeat Steps 4 & 5 above.

7 Reassemble seat belt height adjuster to the driver's shoulder belt mounting bracket, using the Torx fasteners removed in step 2. Apply LOCTITE 242 adhesive to the Torx fasteners and torque to 35-50 ft.lbs. Tip: For ease of reassembly, run a 7/16-20 thread chaser through the two threaded holes in the mounting bracket.

RO4HT

RECALL CAMPAIGN