

R06KP

March 13, 2006

Dear Blue Bird Owner:

This notice is sent to you in accordance with the requirements of the National Traffic and Motor Vehicle Safety Act.

Blue Bird Body Company has decided that certain 2007 model year Blue Bird Micro Bird school buses mounted on Ford chassis manufactured from December 07, 2006 through January 20, 2006 fail to conform to Federal Motor Vehicle Safety Standard No. 301 "Fuel System Integrity". Blue Bird is conducting a recall to correct this noncompliance.

The nonconformance relates to the rear bumper. Certification of the Ford chassis to FMVSS 301; "Fuel System Integrity" requirements is based on the provision of a protective steel cage by the final stage manufacturer. The rear bumper installed by Blue Bird does not meet Ford's certification requirements for a 10" bumper as part of the protective steel cage. The original bumper and brackets must be removed and replaced with a 10" rear bumper and brackets.

Blue Bird's evaluation of the risk to motor vehicle safety reasonably related to this noncompliance is in the event of a crash, the rear bumper may inadequately protect components of the fuel system. This could result in a post-crash fuel leak which, in the presence of an ignition source, could result in a fire.

Buses with the noncompliance must be corrected by removing the original bumper and replacing it with a replacement 10" rear bumper. Blue Bird will provide the replacement bumpers "No Charge".

Your Blue Bird bus(es) affected by recall R06KPS are identified by body serial number(s) on the enclosed reply sheets.

If you no longer own the subject bus(es), please complete the appropriate section of the pink reply sheet and return to Blue Bird in the enclosed pink postage prepaid envelope.

To receive parts and instructions required to correct this condition, confirm your correct **shipping** address, sign and return the enclosed **yellow** parts request sheet and return it to Blue Bird in the enclosed **pink** postage prepaid reply envelope. Parts to complete R06KP are available and will be shipped via common carrier from our manufacturing facility in Brantford Ontario.

A qualified technician should perform this modification or you may contact your Blue Bird distributor for assistance. Reimbursement for labor may be obtained by completing the pink request for reimbursement sheet provided and returning it to Blue Bird in the enclosed pink postage prepaid envelope. Labor time required to perform recall R06KP is 1.5 hours per bus.

If the modifications/repair directed by this notification was performed on your bus prior to the receipt of this recall notification, complete and sign the recall reply sheet and attached a copy of the work order/invoice. Mail the documents in the pink self-addressed postage paid envelope included with the recall notification to Blue Bird for warranty consideration. Reimbursements will be made in accordance with the requirements of the National Highway Transportation Safety Act, title 49 Code of Federal Regulations, Parts 573 and 577.

Federal law requires that any vehicle lessor receiving this recall notice must forward a copy of this notice to the lessee within ten days.

If Blue Bird Body Company should fail to or is unable to remedy this condition without charge to you, you may contact:

**ADMINISTRATOR
NATIONAL HIGHWAY TRAFFIC SAFETY ADMINISTRATION
400 SEVENTH STREET, SW
WASHINGTON, D.C. 20590**

or you may call The National Highway Traffic Safety Administration toll free at:

1-888-327-4236
(TTY: 1-800-424-9153); or go to <http://www.safercar.gov>

Questions regarding this recall campaign should be directed to me at (478) 822-2242.

Thank you,

Bill Coleman
Recall Administrator
BLUE BIRD BODY COMPANY

RECALL R06KP
INSTRUCTIONS FOR REPLACING REAR BUMPER ON BLUE BIRD MICROBIRD

1. Park vehicle on level surface, remove keys and chock wheels.
2. Remove original bumper.
3. Install replacement bumper. See diagram below.
4. Torque bolts to 70-80 lb. ft.
5. Remove wheel chocks.
6. Discard original bumper and brackets.

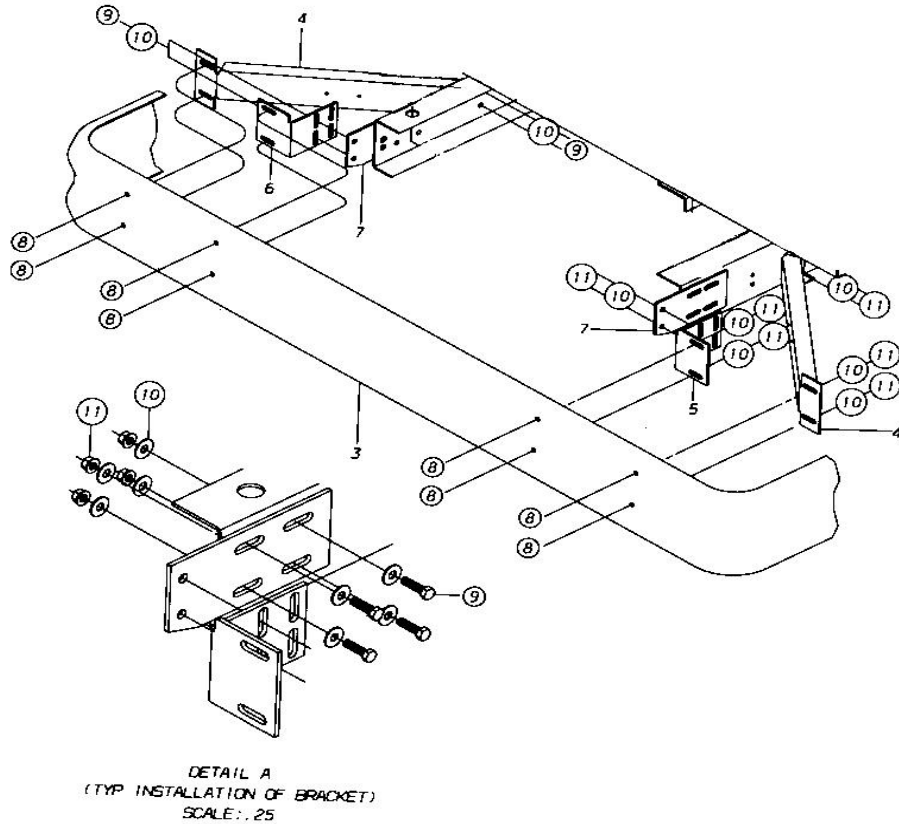

PARTS LIST:

Key No.	Part No.	Description	Qty
3	1312479	Bumper, Rear, 10 inch	1
4	0037699	Brace, Bumper 10 inch, rear	2
5	0025208	Bracket, Mounting, RR Bumper, Flat Floor, RH	1
6	0025209	Bracket, Mounting, RR Bumper, Flat Floor, LH	1
7	0037399	Bracket, Attaching, Bumper to Chassis	2
8	2089654	Bolt, Carriage, 1/2-13 x 1 1/2, grade 8,	8
9	0803148	Capscrew, Hex Head, 1/2-13 xc 1 3/4 grade 8	16
10	0850776	Washer, flat, 17/32 x 1 1/16 x 3/32	40
11	1003094	Nut, Hex Head, 1/2-13, Grade 8	24