

**BLUE BIRD**

**R08MV**

**DATE: May 08, 2008**

**TO: U.S. DEALERS**

**SUBJECT: RECALL R08MV BATTERY CABLE FUSIBLE LINK OMITTED**

This notice is sent to you in accordance with the requirements of The National Traffic and Motor Vehicle Safety Act.

Blue Bird Corporation has decided that a defect which relates to motor vehicle safety exists in certain 2001 through 2008 model year Blue Bird Micro-Bird school and non-school buses manufactured with an optional battery compartment and mounted on a Ford E-Series cutaway chassis.

The defect involves the fusible link which is provided on the Ford chassis power cable. The fusible link was removed when the cable was shortened to accommodate an optional battery compartment. In the event of an electrical short in the power supply cable, the absence of the fusible link creates the potential for a vehicle fire which may result in property damage, personal injury or death.

Blue Bird is conducting a recall to correct this defect. Buses with the defect must be modified according to instructions provided with recall R08MV, copy enclosed.

If our records indicate affected buses were delivered in your service area, a printout identifying affected buses is enclosed. **Dealers should verify correct owners and assure that complete shipping addresses are provided for each listed vehicle.**

If you have in your possession or have sold a bus that was purchased from another distributor that may be affected by this recall, please notify me at 478-822-2242.

Labor time required to perform Recall R08MV is one (1) hour per bus. Warranty applications may be submitted to Blue Bird ClaimTrac (use create campaign/bulletin claim).

Federal law requires that any vehicle lessor receiving this recall notice must forward a copy of this notice to the lessee within ten days.

**BLUE BIRD CORPORATION**  
402 Blue Bird Blvd. PO Box 937 • Fort Valley, Georgia 31030  
(478) 825-2021

Dealers are reminded of their responsibilities under section 154 of The National Traffic and Motor Vehicle Safety Act of 1991. Dealers are required to complete modifications on units in their inventory before delivering to the final owner. Reference Blue Bird Body Company Distributor Memo No. 42-92.

Questions regarding this recall campaign should be directed to me at (478) 822-2242.

Thank you,

A handwritten signature in black ink that reads "Bill Coleman". The signature is written in a cursive, slightly slanted style.

Bill Coleman  
Corporate Recall Administrator  
Blue Bird Corporation



**R08MV**

May 08, 2008

Dear Blue Bird Owner:

This notice is sent to you in accordance with the requirements of the National Traffic and Motor Vehicle Safety Act.

Blue Bird Corporation has decided that a defect which relates to motor vehicle safety exists in certain 2001 through 2008 model year Blue Bird Micro-Bird school and non-school buses manufactured with an optional battery compartment and mounted on a Ford E-Series cutaway chassis.

The defect involves the fusible link which is provided on the Ford chassis power cable. The fusible link was removed when the cable was shortened to accommodate an optional battery compartment. In the event of an electrical short in the power supply cable, the absence of the fusible link creates the potential for a vehicle fire which may result in property damage, personal injury or death.

Blue Bird is conducting a recall to correct this defect. Buses with this defect must be modified according to the enclosed instructions for Recall R08MV.

Your Blue Bird bus(es) affected by this recall are identified by body serial number(s) on the enclosed reply sheets. If you no longer own the subject bus(es), please complete the appropriate section of the **pink** reply sheet and return to Blue Bird in the enclosed pink postage prepaid envelope.

**To receive parts required to correct this condition, you must return the yellow parts request sheet in the pink self addressed postage prepaid envelope.**

A qualified technician should perform Recall R08MV or you may contact your Blue Bird dealer for assistance.

Labor time required to perform Recall R08MV is one (1) hour per bus. Reimbursement for labor may be obtained by completing the **pink** request for reimbursement sheet provided and returning it to Blue Bird in the enclosed **pink** postage prepaid envelope.

**BLUE BIRD CORPORATION**  
P.O. Box 937 • Fort Valley, Georgia 31030  
Phone: (478) 825-2021

If the modifications directed by this notification were performed on your bus prior to the receipt of this recall notification, complete and sign the recall reply sheet and attached a copy of the work order/invoice. Mail the documents in the **pink** self-addressed postage paid envelope included with the recall notification to Blue Bird for warranty consideration. Reimbursements will be made in accordance with the requirements of the National Highway Transportation Safety Act, Title 49 Code of Federal Regulations, Parts 573 and 577.

Federal law requires that any vehicle lessor receiving this recall notice must forward a copy of this notice to the lessee within ten days.

If Blue Bird Body Company should fail to or is unable to remedy this condition without charge to you, you may contact:

**ADMINISTRATOR  
NATIONAL HIGHWAY TRAFFIC SAFETY ADMINISTRATION  
1200 NEW JERSEY AVENUE, SE  
WASHINGTON, D.C. 20590**

Or, you may call The National Highway Traffic Safety Administration toll free at:

1-888-327-4236  
TTY 1-800-424-9153

Or, go to: [HTTP://WWW.SAFERCAR.GOV](http://WWW.SAFERCAR.GOV)

Questions regarding this recall campaign should be directed to me at (478) 822-2242.

Thank you,



Bill Coleman  
Corporate Recall Administrator  
**BLUE BIRD CORPORATION**



# Chassis Fuse Block Fusible Link

# RECALL

**MODELS AFFECTED:** Ford Micro Bird (A1VC & B2VC) with optional battery compartment, manufactured from December 14, 2000 to September 5, 2007.

## ISSUE

Ford's chassis fuse block fusible link overload protection was inadvertently removed from fuse block electrical power supply cable.

## CORRECTIVE ACTION

Install fusible link in Ford's fuse block electrical power supply circuit.

**WARNING** Always follow all federal, state, local and shop safety standards, and use proper safety equipment when performing this procedure.

## PROCEDURE

- 1** Procedure may be performed with bus lifted on a lift or on a level surface. If no lift is available, park the bus on a level surface, remove ignition key and chock rear wheels.
- 2** Disconnect battery cables, negative first and then positive.
- 3** Locate existing electrical junction block on outside of right hand frame rail behind entrance door stepwell.
- 4** Place new junction block (BB #0553131) against frame two inches above existing junction block and mark the location of 2 mounting holes. See page 2.

**CAUTION** Check inside the right hand frame rail for tubing, hoses and electrical harness components for interference before drilling junction block mounting holes.

- 5** Drill marked mounting holes in frame rail using a 5/16" drill bit.
- 6** Install junction block with bolts (BB #2000057), flatwashers (BB #1247709), lockwashers (BB #0962716) and nuts (BB #2001329). Torque bolts to 10 ft/lbs. See page 2.
- 7** Remove existing junction block stud nut and lockwasher and remove the red Ford fuse block power supply cable from the stud.
- 8** Install one end of fusible link (BB #0125448) on existing junction block stud and reinstall lockwasher and nut. Torque stud nut 5 to 8 ft/lbs.

- 9** Install red Ford fuse block power supply cable removed in step 8 and the remaining end of fusible link cable #0125448 on new junction block stud using lockwasher (BB #2028579) and nut (BB #2001451). Torque stud nut 5 to 8 ft/lbs.
- 10** Apply red enamel glyptal sealant (GE 1201) or equivalent to both junction block studs and cable ends for corrosion protection.
- 11** Locate Ford fuse block under engine hood near radiator. Begin at fuse block and install 8 feet of Split Loom (BB #2272870) on red power supply cable.
- 12** Reconnect batteries cables, positive first and then negative.
- 13** Start engine and check operation of bus electrical systems.
- 14** Return bus to service.

## PARTS LIST

PART NUMBER	QTY. PER BUS	DESCRIPTION
0125448	1	Wire, Fusible Link
0553131	1	Junction Block
0870477	2	Bolt, 1/4-20
1247709	2	Flatwasher, 17/64 ID X 5/8
2001170	2	Lockwasher, split ring 1/4"
2001329	2	Nut, 1/4-20
2001451	1	Nut, 3/8-16
0882795	1	Lockwasher, split ring, 3/8"
2272870	8 ft	Loom, split, 1/2" ID
*GE 1201	As Needed	Glyptal Sealant

\*Procure GE 1201 or equivalent Glyptal Sealant, locally.

R08MV

S E R V I C E R E C A L L



# RECALL

**R08MV**  
S E R V I C E R E C A L L

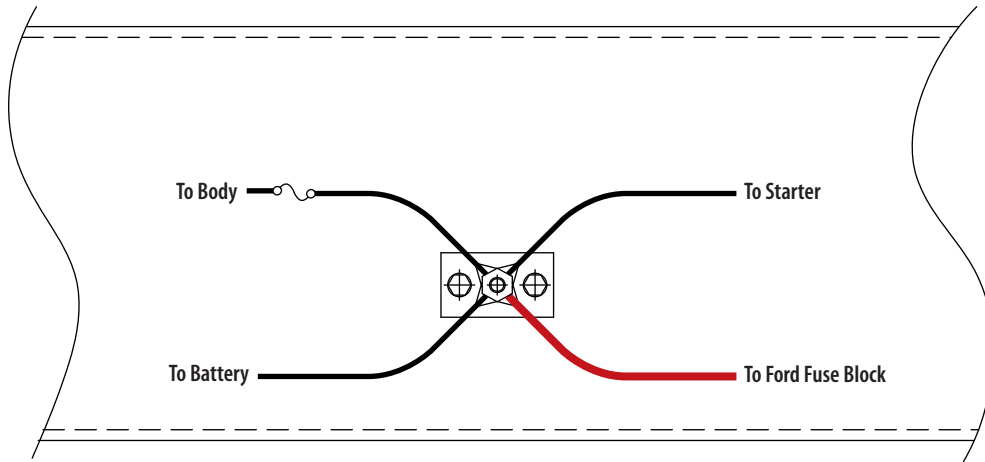

*Righthand Frame Rail  
Existing Connection*

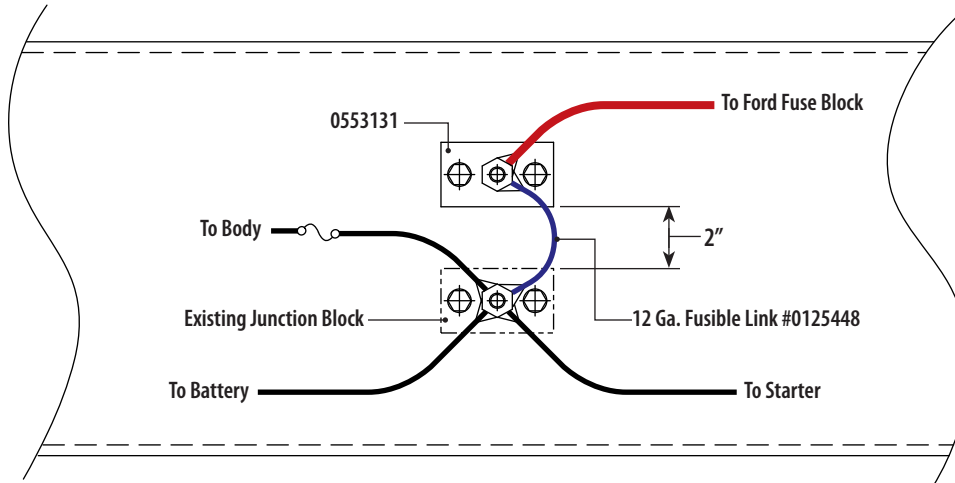

*Righthand Frame Rail  
Modified Connections*

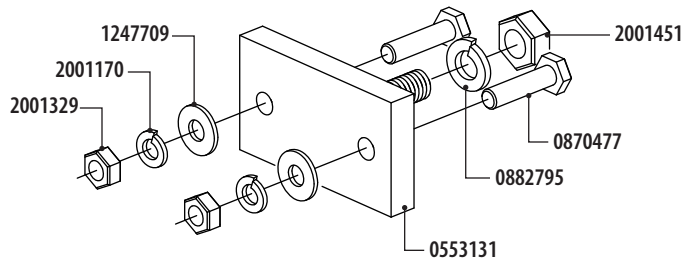

*Junction Block Detail*