

## **R99DK**

December 15, 1999

Dear Blue Bird Owner:

This notice is sent to you in accordance with the requirements of the National Traffic and Motor Vehicle Safety Act.

Blue Bird Body Company has determined that a defect which relates to motor vehicle safety exists in certain 1999 and 2000 year model Blue Bird TC/2000 school and transit front engine buses and Commercial Series front engine buses equipped with optional Hendrickson Parasteer front air suspension. Blue Bird is conducting a recall to correct this defect.

The defect involves the potential occurrence of a shimmy in the front end when the bus hits a bump or pothole. An axle damper must be installed to eliminate the potential for shimmy in the front end.

Blue Bird Body Company's evaluation of the risk to motor vehicle safety reasonably related to this defect is if shimmy occurs the driver could react by overly aggressive steering or braking which could result in an accident.

Your Blue Bird bus (es) affected by recall R99DK are identified by body serial number(s) on the enclosed reply sheets. If you no longer own the subject bus (es), please complete the appropriate section of the yellow reply sheet and return to Blue Bird in the enclosed pink postage prepaid envelope.

You may perform this modification yourself or have the work done by a qualified repair facility convenient to you. You may contact your Blue Bird distributor for assistance.

To receive parts to correct this defect, verify correct shipping address on the yellow reply sheet and return to Blue Bird in the pink self-addressed postage paid envelope. Parts will be shipped "No Charge" via UPS or common carrier.

Upon completion of the recall the owner should complete and return the pink reply sheet in the postage prepaid envelope provided. The owner may request reimbursement of labor costs by completing the appropriate section of the pink reply sheet. If repair is performed by other than the owner or a Blue Bird distributor, attach a copy of the paid work order/invoice to the reply sheet. Time required to perform recall R99DK is 2.5 hours per bus

**R99DK**

**Page 2**

Important: Your prompt return of the pink reimbursement sheet, complete with the correct Body Serial Numbers, permits Blue Bird to update the record indicating recall has been completed and prevents the mailing of a second notice. This is much appreciated. We regret any inconvenience this may have caused.

If Blue Bird Body Company should fail to or is unable to remedy this condition without charge to you, you may contact:

**ADMINISTRATOR  
NATIONAL HIGHWAY TRAFFIC SAFETY ADMINISTRATION  
WASHINGTON, D.C. 20590**

or you may call The National Highway Traffic Safety Administration toll free at:

1-800-424-9393

Washington D.C. residents may call: 202-366-0123.

Questions regarding this recall campaign should be directed to me at (912) 822-2242.

Thank you,

Bill Coleman  
Recall Administrator

**BLUE BIRD BODY COMPANY**

**RECALL R99DK  
HENDRICKSON PARASTEER  
AXLE DAMPER INSTALLATION INSTRUCTIONS**

1. Park bus on level surface and remove keys from ignition.
2. Chock wheels.
3. Detach both the left and right front shock absorber at the lower bushing by removing the 3/4" locknut and removing bolt attached to the axle seat. Discard original bolts washers and nuts.
4. Detach the ABS valves at each side of the frame rails.
5. Position the crossmember (item 1) on the bus behind the front suspension air springs. See Figure 1. Use the upper front hole of the ABS valve at each side of the rail to position the crossmember on the frame rails. See Figure 2.
6. Once the crossmember is placed and leveled on the bus, mark the six (6) holes of the crossmember in the frame rails. See Figure 2.
7. Drill six (6) .625 holes at the marks you made on the frame rails. See Figure 2.
8. Install the cross member to the frame rails with six (6) 5/8" x 2 1/4 in bolts (item 9), twelve (12) 5/8" hardened washers (item 10) and six (6) 5/8" locknuts (item 11). See Figure 1. Torque fasteners to 150-205 ft. lbs.
9. Attach the lower bushing of the left shock absorber together with the axle seat shock bracket (item 4) to the axle seat with 3/4" x 4 1/4" hex bolt (item 6), 3/4" hardened washer (item 5) and 3/4" locknut (item 8). Torque fasteners to 50-70 ft. lbs.
10. Re-attach lower bushing of right shock absorber with 3/4" x 4 1/4" hex bolt (item 6), 3/4" hardened washer (item 5) and 3/4" locknut (item 8). Torque fasteners to 50-70 ft. lbs.
11. Attach the crossmember shock bracket (item 2) to the crossmember with two (2) 3/4" x 2 1/4" bolts (item 7), four (4) 3/4" hardened washers (item 5) and two (2) 3/4" locknuts (item 8). Torque fasteners to 50-70 ft. lbs.
12. Assemble the stabilizer shock absorber (item 3) to the two brackets (items 2 and 4) using 3/4" x 3 3/4" hex bolt (item 12) 3/4" hardened washer (item 5) and 3/4" locknut (item 8). See note 3 on page 2 for shock installation. Torque fasteners to 50-70 ft. lbs.

Note:

1. Replace all used locknuts with new locknuts provided in kit.
2. Follow the recommended torque for fastening the hardware provided in the service kit.
3. Position stabilizer shock (item 3) with large end toward outside of bus as shown in illustration at bottom of Figure 1.

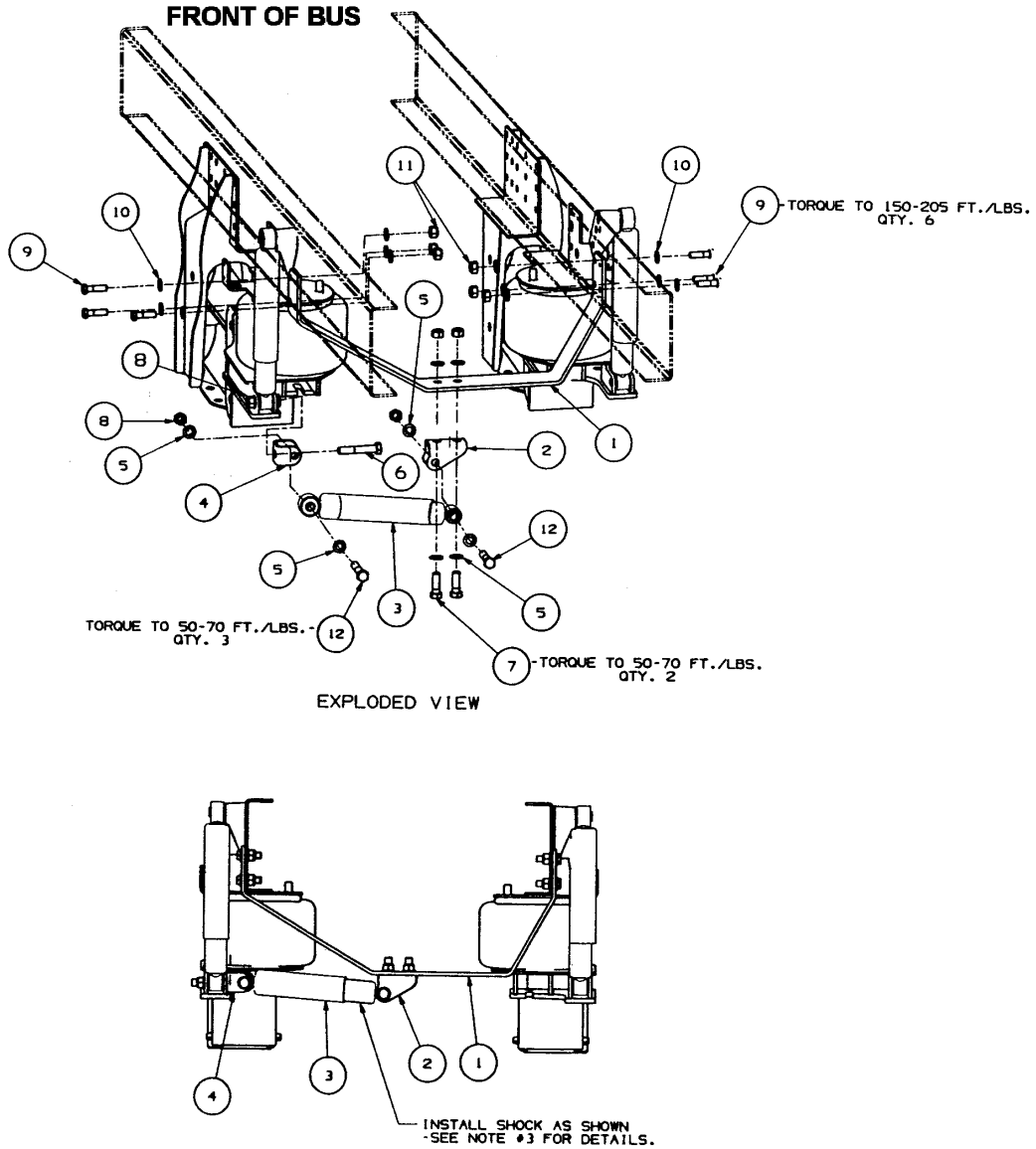

Figure 1

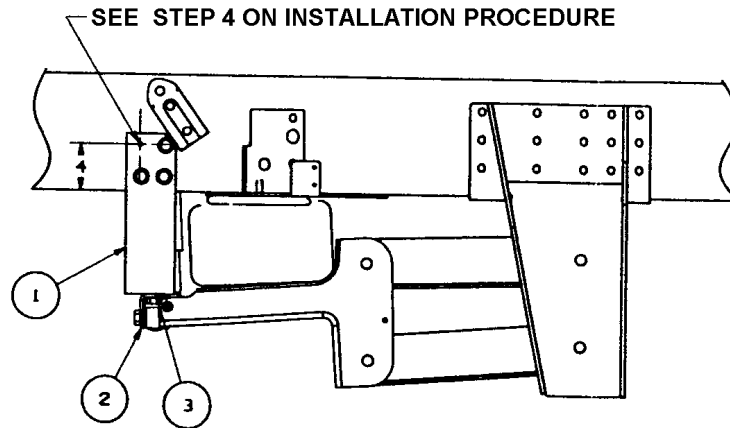

Figure 2

## Parts List:

Item No.	Quantity	Description
1	1	Crossmember
2	1	Crossmember shock bracket
3	1	Stabilizer shock
4	1	Axle seat shock bracket
5	10	3/4" hardened washer
6	1	3/4" x 4 1/4" hex bolt
7	2	3/4" x 2 1/4" hex bolt
8	5	3/4" locknut
9	6	5/8" x 2 1/4" hex bolt
10	12	5/8" hardened washer
11	6	5/8" locknut
12	2	3/4" x 3 3/4" hex bolt